



Pre-Plumb Addendum



PRE PLUMB UNIT

Issue 4

INTRODUCTION

These instructions are designed to be read in conjunction with the main product instruction manual. Particular attention should be paid to all appertaining legislative requirements including Building Regulations, Water Regulations, IEE Wiring Requirements and Good Practice. This Installation should only be conducted by a person competent to do so.

This Pre-Plumb unit is a Stainless Steel Unvented Indirect Hot Water Storage Cylinder with factory built hot water and central heating controls assembled onto the front outer case of the cylinder. The cylinder may be a single coil indirect for connection to a fossil fuel boiler or a twin coil unit for integration with a solar panel system, which in this instance, the pre-plumb controls are assembled onto the upper coil.

In addition to those components supplied with a standard (non pre-plumb) the following are included:

Qty	Equipment Supplied With Cylinder	Supplied
1	ESI 2 Channel Programmer (Twin Zone - 307XLS)	Loose
1	ESI Room Thermostat (Twin Zone - Requires 2)	Loose
2	ESI SZM1811 2 Port Motorized Valve	Fitted
1	Wiring Centre	Fitted
1	Dual Probe Hot Water / High Limit Control Thermostat	Fitted
1	ESI SBV Auto Bypass Valve	Fitted
1	Wilo 6mtr Circulating Pump C/W Gate Valves	Fitted
1	Auto Air Valve	Fitted
1	Sealed System Filling Loop	Fitted
1	Primary Manifold Collector C/W Expansion Valve & Gauge	Loose
1	Primary Expansion Vessel (120-210 = 12L Exp , 250 = 18L Exp , 300 = 24L Exp)	Loose

POTABLE WATER CONNECTIONS

The potable (secondary) water connections are 22mm compression and are connected under the same manner as listed in the main Instruction Manual. These connections include; Cold Mains to Inlet Control Set, Equalised Cold Supply from Inlet Control Set, Hot Water Draw Off, Secondary Return Connection (where fitted), Expansion Vessel, Vessel Bracket and Vessel Fitting, Tundish Discharge Pipework.

PRIMARY WATER CONNECTIONS

All primary pipework connections are 22mm compression with gland nut and olive at each connection point and require connection in the standard method.

Boiler flow;- Remove and discard the transit pipe under the circulating pump by releasing the outer of the pipe clamp and the gland nut to the Pump Isolation Valve. Connect the boiler flow pipework directly into the pump isolation valve re-using the pipe clamp to provide support to both the pipework and circulating pump.

Heating flow;- Connect from the 2-port heating valve/s the heating flow into the radiator circuit.

Heating Return;- The heating return pipework returns back into the pre-plumb cylinder pipework connecting to the 22mm connection on the left hand side of the unit adjacent to the dual cylinder thermostat.

Boiler Return;- The pipework connection from both the central heating and the hot water circuit is the lower left 22mm connection below the heating return. This connection requires piping directly back to the boiler.

Primary Expansion;- The Pre-Plumb unit is supplied c/w a manifold connector facilitating the expansion vessel, expansion discharge valve and pressure gauge. The assembly is usually installed in the pipework adjacent to the boiler appliance - see both boiler manufacturers requirements and instructions provided with the components supplied. Check the vessel is charged to 1.5bar on installation. Ensure the discharge pipe terminates at a point where the discharge of hot water is visible, yet does not cause danger to persons.

WIRING REQUIREMENTS

Pre-Plumb wiring requirements are as per the diagram on the back page of these instructions.

The factory assembled Pre-Plumb wiring detail is shown to the lower section of the connector block complete with the plug in connector detail.

The upper section of the wiring to the connector block depicts connections to be created by the installer.

SYSTEM FILLING & COMMISSIONING

Once all plumbing and wiring is complete the primary system may be filled and flushed in the proprietary manner. Before filling ensure all drain points and air valves etc are fully closed. Fill via the filling loop ensuring the 2 port valves and circulating pump isolation valves are fully open.

Release all air from the auto air valve at the highest point of the pre-plumb pipework and also any other high points in the system. The normal fill pressure is 1.0 Bar to 1.5 Bar - check both boiler and radiator manufacturers requirements. During filling ensure all plumbing connections including factory made connections on the pre-plumb unit are fully water tight and do not leak. Whilst every care is made to ensure these connections are watertight prior to leaving the factory the effects of transit may cause some connections to subsequently leak upon filling for which RM Cylinders can accept no responsibility for damage or inconvenience caused.

Once the system is full of water and devoid of air turn on the boiler appliance and thermostats and heat both hot water and heating circuits. Recommended hot water storage temperature is 60°C. Adjust the auto bypass valve as per manufacturers instructions included in the pack. Check all components are functioning correctly and that there are no leaks present.

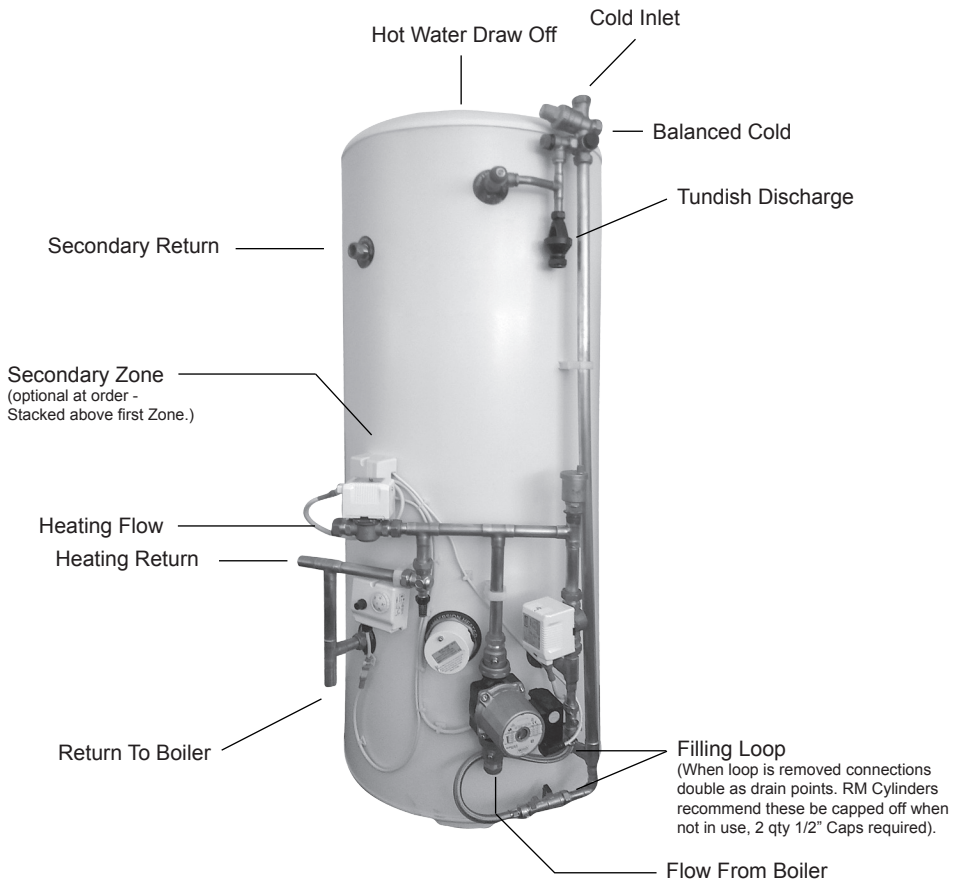

INSTALLER ON-SITE WIRING REQUIREMENTS

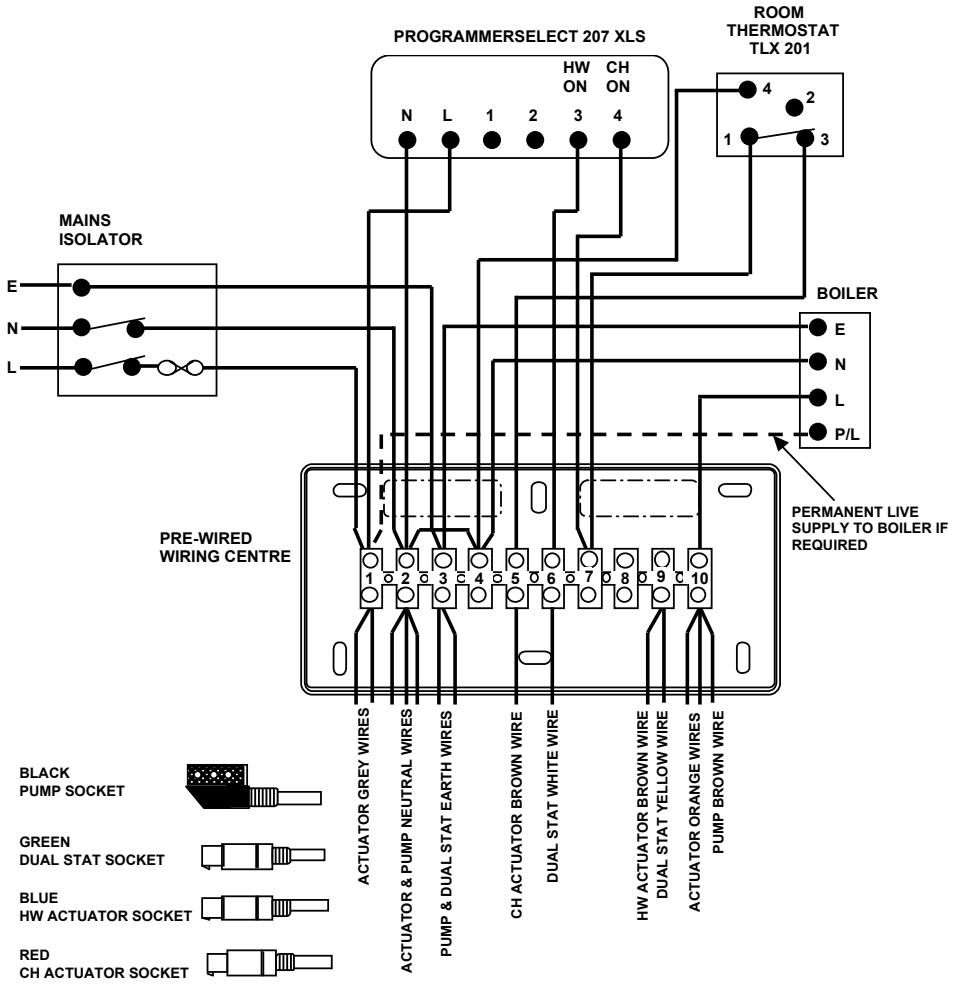

FACTORY PRE-WIRED CONNECTIONS



RM Cylinders

Unit 4, Gilcar Way, Wakefield Europort, Castleford WF10 5QS
 Tel: 01924 228999 Fax: 01924 228990 Web: www.rmcyinders.com